



1/2" Disc Type Thermostat
High Temp. Manual Reset

Type **15N**

UL-C-UR-VDE
Recognized

Dimensions

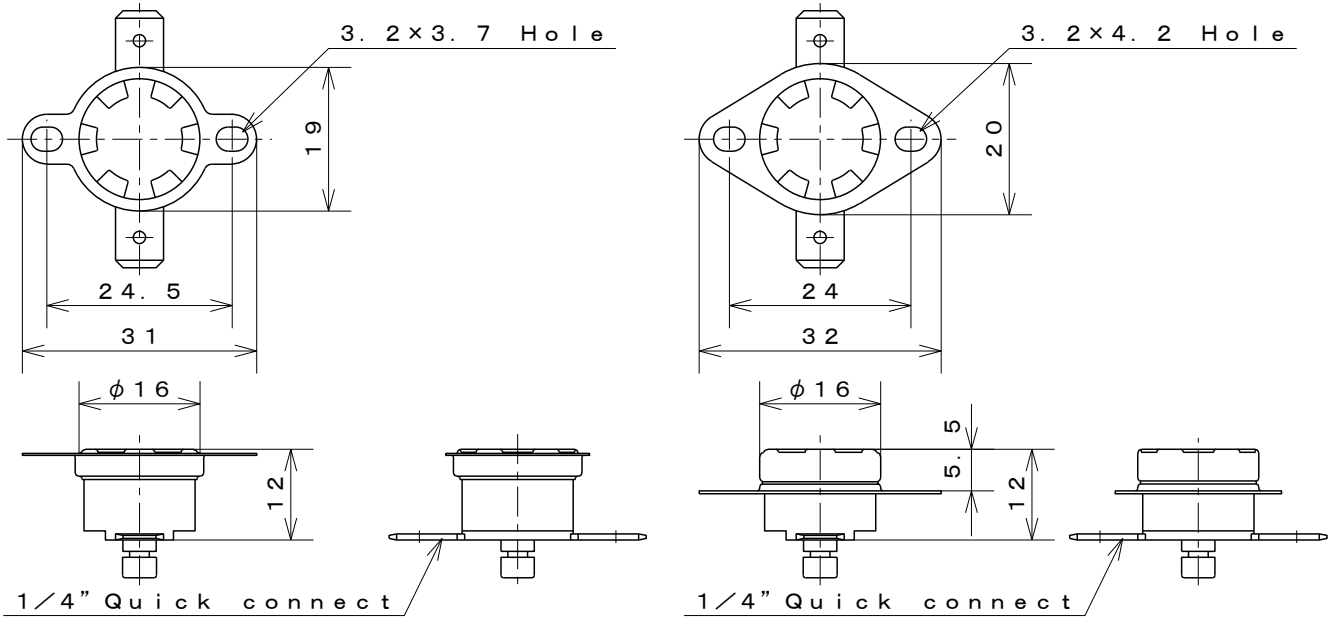

Materials of parts

Part	Material
Cap	Aluminum
	Copper
	Stainless steel
Case	Ceramic
M.arm	Beryllium Copper alloy
Terminals	Steel
Bracket	Stainless steel
Contacts	Silver-Nickel alloy (N)

Structure

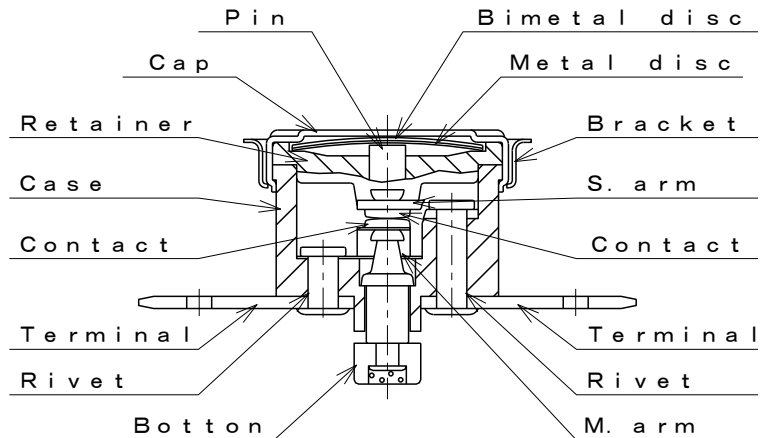

Specification

Item	Specification
1. Basic features	SPST Manual reset
2. Operation	A : Contacts open on temperature rise Not automatic reset
3. Electrical rating	AC250V/16A AC250V/10A
4. Calibration method	Hot & cold air circulation system
5. Temperature rating	Operating temperature Max. 250°C
6. Insulation resistance	Not less than 1,000MΩ/DC500V
7. Dielectric strength	Not less than AC1,500V/1min. or AC1,800V/1sec.

Standard

MITI (JET)	J-58	UL File	No. E201152
UL 60730-1, -2-9		C-UR	
CAN/CSA E730-1, -2-9		VDE Licence	No. 40019831
DIN EN 60730-1, -2-9			